

Specifications

Dyna Pro
Dynamometers

S68-LC (Medium Inertia)

Redefining Industry Standards

Dynamometers & Accessories (EU Specification)

Dyna Pro S68-LC Chassis Dynamometer with Eddy-Brake



Designed and Manufactured in the UK

General Technical Specifications

Maximum Power (Dynamic)	600 hp	Vehicle Type	Bike
Maximum Power (Static)	270 ft/lb.	Loading Type	Inertia & Eddy Brake
Maximum Rear Wheel Speed	200 mph	Speed Encoder System	Digital
Modeled Mass	136 Kg (299 lbs.)	Ignition Pick-up	Digital (Intelligent Pri, & Sec)
Drive Roller Diameter	45.3 cm (17.83")	Data Acquisition System	Digital High-Speed USB
Drive Roller Width	45.0 cm (17.71")	Length (Without Ramp)	270.4 cm (106.46")
Drive Roller Inertia	7.0 Kg/m ²	Width	179.8 cm (70.78")
Drive Roller Surface	Knurled (Anti-Corrosion Zinc)	Height (Deck)	44.9 cm (17.68")
Maximum Bike Length	239.6 cm (94.33")	Height (Overall)	88.4 cm (34.80")
Minimum Bike Length	120.6 cm (47.48")	Weight (Un-Crated)	950 Kg (1650 lbs.) (Approx.)
Timing Accuracy	50 nano seconds		
Speed Accuracy	0.01 mph	Supply Voltage	190 - 240 Volts ac 50/60 Hz
RPM Accuracy	0.1 rpm	Maximum Supply Current	20 Amps
Calibration	Factory Calibrated	Air Consumption	<1 CFM (120 psi Max)

Standard Accessories

- Dyna Run V4 Advanced Windows Software (Windows 10/11).
- Dynamometer to PC USB Link
- Eddy Brake Torque Monitor fitted as standard.
- Intelligent Ignition Pick-up System (Primary and Secondary Side).
- Starter System fitted as standard (Also used to calibrate Dynamometer).
- Air Brake System (With emergency lock-down in the event of power failure.)
- 12 Auxiliary 0-5 Volt Data Acquisition Inputs, for connection to additional sensors.
- Calibration Check Weight and Arm.

Key Features

- Machine Construction from 3, 5 & 10mm Precision Laser Cut steel, powder coated finish, Blue & Yellow.
- Eddy brake system fully Closed-Loop with compensation.
- Fast Dynamic Load Control of Eddy Brake (No user PID control, Self-learning)
- Torque Monitor fitted to Eddy Brake as standard.
- Dyna Pro has a continuously ongoing Research and Development Program.
- Designed and Manufactured in the UK
- 1 Day Training (at Dyna Pro Works)
- 2 Year replacement parts warranty. (excluding consumables)

Optional Accessories

- Twin Cooling Fans System (High Speed, High Pressure - Operated from Hand Control Pendant). ***
- Wideband Air Fuel System. (Single Channel***, Double Channel and Quad channel).
- Weather Station (Temperature, Humidity, Pressure & Relative Air Density). ***
- Gas assisted Loading Ramp. ***
- Keyboard Monitor Shelf. ***
- Ram Air simulation System (Calibrated to road speed).
- 4 Channel Type K Thermocouple Unit.
- Exhaust Extraction Kit.
- Exhaust Arms.
- Carbide Drive Roller Coating.
- Infrared Temperature monitor (up to 500°C).

Dimensions & Clearance

*Dynamometer show with optional Gas Ramp Fitted

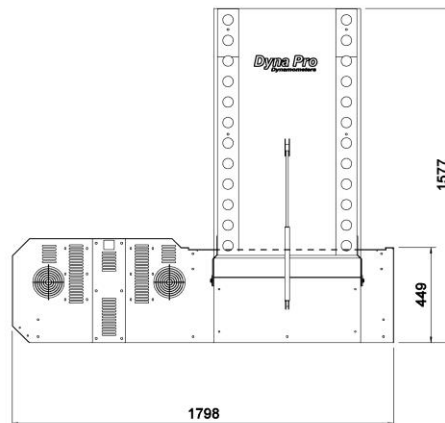
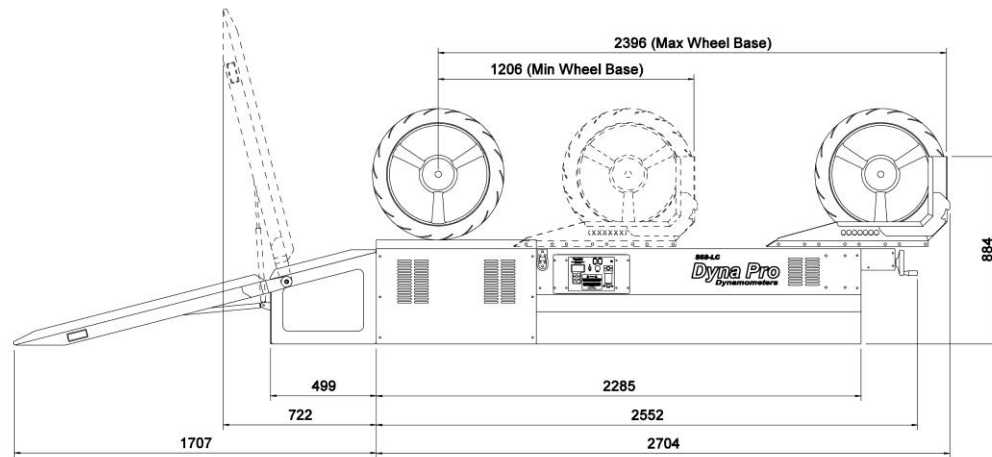
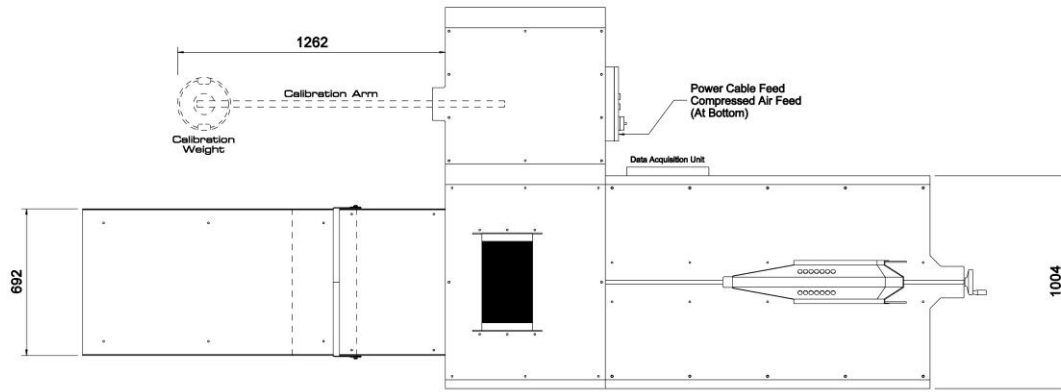

Electrical

200-240V ac Single Phase
 Max Current 32 Amps
 Fuse at 32 Amps
 4mm² Minimum Cable size recommended

Air Supply

90 to 120 PSI
 Less than 1CFM

Items shown **** above come as standard with the show package deal.

Specifications are correct at time of print, manufacturer's specification subject to change without notice.

Copyright © Dyna Pro Dynamometers Limited 2024

Dyna Pro Dynamometers Ltd

Unit 18, Sherrington Way, Lister Road Industrial Estate, Basingstoke, Hampshire, UK. RG22 4DQ

Tel (Int.): +44 (0)1256 363063

www.dynapro.co.uk E-mail: sales@dynapro.co.uk